

APRIL 1, 1972

CHEVROLET

CORVETTE 1963-67

FRONT BUMPER

R&R Bumper Assembly .5
 O/H Includes R&R .7
 Brace Time in w/Bumper removed.

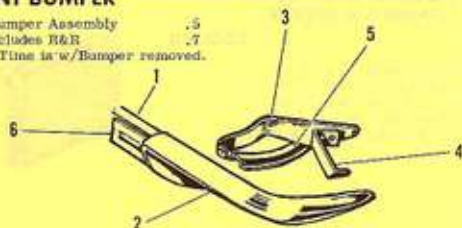

1. Face Bar			
Center	3797439	.4	8.13
Outer	3797338-7	.2	43.40
2. Brace, To Frame			
Center			
63-64	3848214-3	.2	2.92
65-67	3865406-5	.2	2.92
Outer	3848218-7	.2	1.59
Inner	3848220-19	.2	2.92
3. Bracket, License	3878898	.77	
Frame, License	3797485	4.00	
Bumper, License	3762190	.20	

GRILLE

1963-64

O/H Includes R&R 2.3
 Bars are numbered from top to bottom.
 R&R Bars including R&R Grille Assembly
 One 1.3, Each Additional .3
 Refinish Upper Panel 1.3
 Lower Panel .6

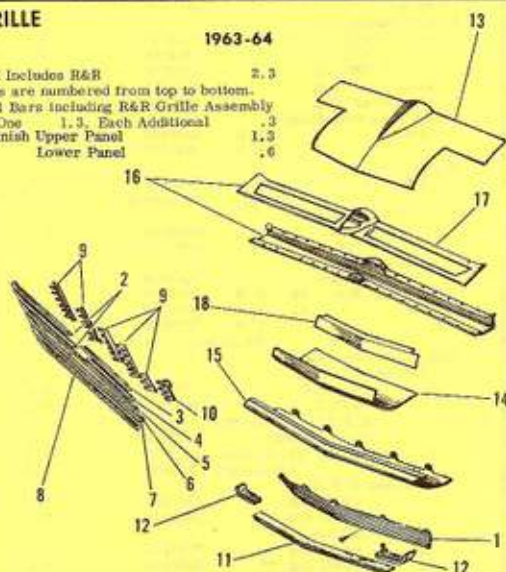

1. Grille Assembly *	3846941	.9	41.50
Bar, Grille			
No. 1 & 2 Inner	3830150	#	5.64
No. 1 Outer	3830152-1	#	1.44
No. 2 Outer	3830154-3	#	1.44
No. 3	3830155	#	5.45
No. 4	3830156	#	5.45
No. 5	3830157	#	5.35
No. 6	3830158	#	5.15
	(*SEE Note Above.)		
Support, Grille			
Center, Inter., Outer Lwr.	3831928	.15	
Upper Outer	3830162-1	.30	
	(*Includes Items 2 thru 10.)		
Moulding, Grille			
Center	3797235	.3	5.75
Side	3797234-3	.3	2.72
Bracket, Grille Mounting (2)	3831933	.10	

GRILLE, Cont'd.

Panel, Grille			
13. Upper, Upper Half	3864695	#5.7	44.25
14. Lower Half	3831931	2.6	9.65
15. Lower	3831932	*2.2	12.45
	(*Includes R&R Lower Half Item 14. R&R Items 13 & 14 w/Front Fender adjacent parts removed (3,5) (*R&R w/Bumper removed 1,8)		
16. Reinf. Assy., Upper Panel *	3914068	# 2.0	29.40
17. Bonding Strip, Reinf.	3859043		9.10
	(*Includes Item 17.) (*w/Outer Panels removed.)		
18. Bonding Strip, Upper Panel Fender to Grille	3797481		3.64
Emblem, Upper Panel "Crossed Flags"	3797400		3.18

1965-67

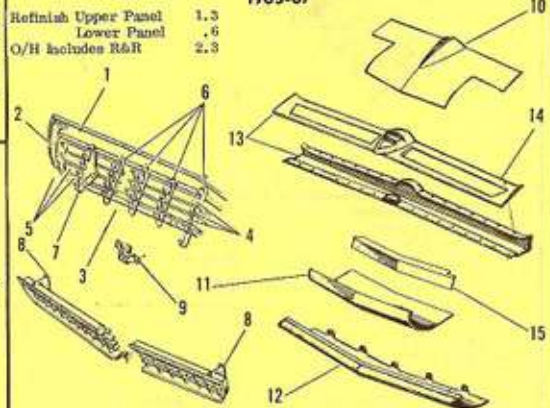

Refinish Upper Panel	1.3		
Lower Panel	.6		
O/H Includes R&R	2.3		
Grille Assembly *	3875746	.7	34.25
	(*1965 Grille no longer serviced - Use Grille listed with 2-3897389 Supports. Components for 1965 Grille are still available as listed, Items 1 thru 7.)		
Moulding, Grille (1965 Only)			
1. Upper	3866198	.3	6.20
2. Side	3860534-3	.3	3.23
3. Lower Center	3860578	.3	5.45
Bar, Grille (1965 Only)			
Center (No. 1, 2 & 3)	3860574	#	2.46
Outer (No. 1, 2 & 3) *	3830152-1	#	1.44
	(*Cut as required.) (*R&R One 1.3, each additional .3)		
Support, Grille Bar (1965 Only)			
6. Center & Inter.	3860567	.36	
7. Outer	3860569	.28	
8. Support, Grille Mounting (2)	3897389	.36	
9. Bracket, Grille (4) Panel, Grille	3860570	.10	
10. Upper, Upper Half			
65-66	3864695	#5.7	44.25
67	3904969	#5.7	44.30
11. Upper, Lower Half	3831931	#2.6	9.65
12. Lower	3831932	#2.2	12.45
	(*w/Bumper & Grille removed.)		
13. Reinf. Assy., Upper Panel *			
65-66	3914068	# 2.0	29.40
67	3914068	# 2.0	29.40
14. Bonding Strip, Reinf.	3859043		9.10
	(*Includes Item 14.) (*w/Outer Panels removed.)		
15. Bonding Strip, Upper Panel Fender to Grille	3797481		3.64
Emblem, Upper Panel "Crossed Flags"			
65-66	3872928		3.02
67	3894544		2.92

Cont'd.

CORVETTE 1963-67

CHEVROLET

FRONT LAMPS

O/H Lamp Assembly	
One Side	1.5
	1.4
Both Sides	2.6
	2.3

(#w/Hood removed)
 One Side 1.1
 Both Sides 2.2
 Time Does Not Include Align
 due to Wreck Damage.

Average rework time
 2.0 to 3.0

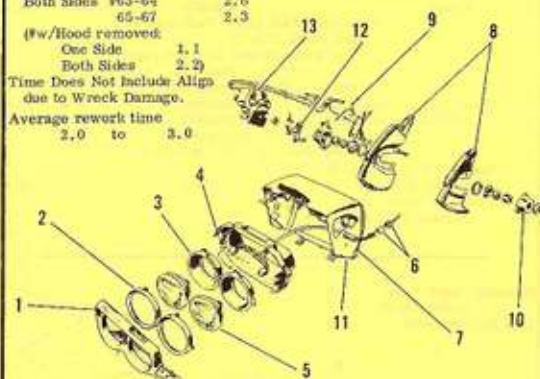

Headlamp Assembly*

63	5953734-3	#	28.80
64-67	Not Serviced - Use Components (#R&R Assembly w/Grille removed .2)		
1. Door or Moulding	3845302-1	.2	9.25
2. Ring, Retainer	5954892		1.85
3. Ring, Adjusting			
63 Inner	R. H. 5955498		1.54
	L. H. 5948825		1.47
Outer	5955498-500		1.54
64-67 Inner (2)	5955498		1.54
Outer (2)	5955500		1.54
4. Body, Sub. (63 Only)	595428-7	(Disc.)	7.20
5. Sealed Beam			
Inner	5956001	#	2.65
Outer	5956002	#	2.65
6. Socket, w/Cable (63 Only)	5954526		5.25
	(*Includes Items 1 thru 6.)		
7. Panel, Lamp Housing			
63 (Complete)	3859034-3	.7	28.25
64-67	3845788-7	1.4	15.90
8. End, Opening Cover			
Inner	3824534-3		6.55
Outer	3824530-29		6.10
Support, Cover Pivot			
Inner	3825356-5		4.00
Outer	3825357		2.28
11. Pivot, Opening Cover			
63	Not Serviced - Part of Housing		
64-67 Inner	3845792-1		6.30
Outer	3845790-89		4.25
12. Stop, Opening Cover (2)	3826291	#	4.10
	(#R&R One Side .7, Both Sides 1.1 Adjust One Side .2, Both Sides .4)		
13. Motor, w/Support	5945374-5	#, 6	81.40
	(#Both .8)		

PARKLAMP



1. Lamp Assembly	910552	.2	6.65
2. Lens (2)	5954440	.2	1.03
3. Gasket, Lens (2)	5950981		.41
4. Housing	Not Serviced - Use Assembly		
5. Seal, Housing	N. A.	N. A.	
Bulb (No. 1157)	9428902		.54

COOLING & ENGINE

UNDER HOOD ITEMS

COOLING



R&R Any One Radiator Hose w/Radiator removed	.1		
R&R Fan, Pulley &/or Clutch w/Radiator removed	.2		
Pulley Time Includes R&R Belt.			
Radiator			
w/327 Eng. *	3155316	#	112.85
w/396 Eng. *	3007438	#	140.90
w/427 Eng. *			
	3008566	#	199.55
	(*w/o Oil Cooler) (**w/Oil Cooler)		
(#63-64 .4, 65-67 1.2, w/Auto. Trans., Add .2)			
Tank, Supply			
exc. 427 Eng.	3155416	#	16.06
	(#63-64 .5, 65-67 .3)		
Bracket, Supply Tank			
63	3824500		2.61
64-67 exc. 427 Eng.	3843431		.62
Cap, Radiator Filler			
13 Lb. (Aluminum Rad.)	861981		3.64
15 Lb.	6410456		1.79
Support, Radiator			
63-65 w/o A. C., 396 Eng.	3858963	1.4	34.85
w/A. C.	3874768	1.4	32.35
w/396 Eng.	3873736	1.4	35.75
66-67 w/327 Eng.	3894595	1.4	34.10
66-67 w/427 Eng.	3894597	1.4	34.10
Shield, Underbody Splash			
64-67	R. H. 3922440		1.64
	L. H. 3846935		.92
Shroud, Fan			
63-65 w/327 Eng. (Complete)	3829723	.8	11.85
w/396 Eng. (Plastic)	3872996-3	.8	12.30
66-67 w/327 Eng.			
Upper	3888268	#	9.70
Side	3896886-5	#	12.90
66-67 w/427 Eng.			
Upper	3938940	#	31.65
Side 66	R. H. 3938940	#	31.65
67	R. H. 3938940	#	31.65
	L. H. 3938940	#	31.65
	(#Complete .8)		
Hose, Upper Radiator			
63-65 exc. H. P. Eng.			
w/o A. C.	3827366	#, 3	1.74
w/A. C.	3833016	#, 3	1.64
w/H. P. Eng., F/Injection			
exc. 396 Eng.	3827368	#, 3	1.74
65 w/396 Eng. (1st Design)	3873842	#, 3	1.95
(2nd Design)	3879680	#, 3	1.95
66-67 exc. H. P. Eng.			
w/327 Eng.	3887154	#, 3	2.05
w/427 Eng. *	3906616	#, 4	1.99
w/H. P. Eng.			
w/327 Eng.	3887156	#, 3	1.79
w/427 Eng. **	3906615	#, 4	1.95
(*w/Smog Device) (**w/Smog Device)			
(#Upper & Lower .9)			
Hose, Lower Radiator			
63-65 w/327 Eng.	3832170	#, 7	2.97
w/396 Eng.	3876782	#, 7	2.82
66-67 w/327 Eng.	3917669	#, 7	3.18
w/427 Eng.	3882826	#, 7	3.18
	(#Upper & Lower .9)		
Fan Blades			
w/o A. C.			
w/327 Eng. (5 Blades)	3770529	#	10.75
w/A. C.			
w/327 Eng. (5 Blades)	3789562	#	10.50
w/327 Eng. (7 Blades)	3853943	#	10.15
w/or w/o A. C.			
w/396 Eng. (5 Blades)	3872792	#	9.80
w/427 Eng. (5 Blades)	3956182	#	11.60
	(#One Belt .4, Two .5, Three .6)		

Cont'd.

APRIL 1, 1972

CHEVROLET

CORVETTE 1963-67

COOLING & ENGINE, Cont'd.
UNDER HOOD ITEMS

COOLING, Cont'd.

Clutch, Fan Drive w/327 Eng.	3916139	.4	30.15
w/427 Eng.	3916141	.4	30.15
Pulley, Fan*			
Double			
w/o A.C.			
63-65 exc.	3790356	0	4.56
63-66 w/327 Eng., F/Inj.	3770245	0	5.15
66 w/327 Eng. **	3790356	0	4.56
w/A.C.			
63	3905989	0	4.10
64-67 w/327 H.P. Eng.	3848904	0	4.51
Front			
w/o A.C.			
66 w/327 Eng. ***	3905995	0	2.61
66 w/327 Eng. **	3765427	0	7.45
66 w/427 Eng.	3765427	0	7.45
67 w/327 Eng.	3905995	0	2.61
w/A.C.			
66-67 w/327 Eng. **	3883234	0	2.82
66-67 w/327 H.P. Eng. **			
w/o P.S.	3883235	0	2.67
w/P.S.	3883234	0	2.82
Rear			
65-66 w/396 Eng.	3827840	0	2.61
(**w/Smog Device) (***/o Smog Device)			
(#Use Fan Time.)			
(*Also SEE Pulley Assembly.)			
Pulley Assy., w/Pump & Fan			
w/o A.C.			
63 w/396 Eng.	3906656	0	3.59
65-67 w/427 Eng.	3906656	0	3.59
67 w/327 Eng. *	3900434	0	4.51
w/A.C.			
64-67 exc. 427 Eng.	3995643	0	4.05
66-67 w/427 Eng.	3995644	0	7.35
(#Use Fan Time.)			
(*w/Smog Device.)			
Pulley, Idler			
63-66 w/H.P. Eng., F/Inj.	3839182	.3	9.90
Belt, Fan - SEE Note Below			
NOTE: Due to the large number of Belts listed, Call Local Dealer for application & price. (#One Belt .2, Each additional .1)			
Water Pump			
63-67 w/327 Eng.	3998206	#1.0	18.40
65-67 w/396, 427 Eng.	3909953	#1.3	32.30
(#w/A.C. or P.S., Add .2)			

SMOG CONTROL SYSTEM

Pump, Less Pulley			
66-67	7800306	.5	50.25
Pulley, Pump			
Exc. 327 Eng.	3889800	.3	1.18
327 Eng. w/o A.C.	3880800	.3	1.18
w/A.C.	3890421	.3	.77
w/H.P. Eng.	3890421	.3	.77
Belt, Pump			
w/327 Eng.			
w/o A.C., w/o H.P. Eng.	539130	#	3.38
w/H.P. Eng.	3925595	#	3.18
w/A.C.	3883252	#	2.82
w/427 Eng.			
w/o A.C., w/H.P. Eng.	3925595	#	3.18
(#One Belt .2, Each additional .1)			
Bracket, Pump			
w/327 Eng.	3923214	#.2	10.20
w/427 Eng.	3882831	#.2	10.10
(#w/Pump removed.)			
Brace, Pump			
w/327 Eng.			
66-67	3889314		.67
w/427 Eng.			
66	3886109		2.00
67 w/o A.C.	3886109		2.00
w/A.C.	3894368		1.69

Cont'd.

COOLING & ENGINE, Cont'd.
UNDER HOOD ITEMS

SMOG CONTROL SYSTEM, Cont'd.

Hose, Pump Inlet			
w/327 Eng.	3905298	.2	1.44
w/427 Eng.			
66	3884655	.2	1.54
67	3909889	.2	2.00
Hose, Pump Outlet			
w/327 Eng.			
66-67	R. H. 3884378	.2	2.13
	L. H. 3884379	.2	3.08
w/427 Eng.			
66-67	3889356	.2	2.00
Hose, Mixture Valve To Check Valve			
66	3902366	.2	2.00
67 w/327 Eng.	3903366	.2	2.00
w/427 Eng.	3902345	.2	1.49
Valves, Control			
Pump Check			
66-67	R. H. 5354988	.2	4.56
	L. H. 5354987	.2	3.66
Pump Relief			
66-67	5696639	.2	1.95
Fuel Mixture			
w/327 Eng.			
66-67	7033546	.2	10.25
w/427 Eng.			
66-67	7033547	.2	10.25
Muffler, Pump			
Pipe, Gas Combustion			
w/327 Eng., 66-67	R. H. 3877480		5.25
	L. H. 3905297		7.85
Pipe, Injection			
w/427 Eng., 66-67	R. H. 3889348		8.30
	L. H. 3889377		8.30

ELECTRICAL



Horn, w/Bracket			
Lo-Note	9090239	.2	9.30
Hi-Note	9090611	.2	9.50
Relay, Horn			
63-65	1115889	.2	4.39
66-67	1115837	.2	3.30
Horn Ring - SEE Steering Column			
Cap, Distributor			
63-67 exc. F/Inj.	800061	#	5.35
63-64 F/Inj.			
w/o Hi-Lift Cam	1943047	#	5.15
63 F/Inj.			
w/Hi-Lift Cam	1941551	#	8.35
(#.2 exc. w/427 Eng. .4)			

DELCO TRON & PARTS

O/H Delcotron		
5, 5" 1st Design	1.4	
6, 2" 2nd Design	2.4	



Delcotron Assembly, Less Pulley*		
63-67 (42 Amp.)	1100842	.4 74.20
63-65 (52 Amp.)	1100684	.4 79.70
65 (60 Amp.) w/Tr. Ign.	1100697	.4 81.03
66-67 (61 Amp.)	1100849	.4 80.45
63-66 (62 Amp.) 1st Design	1117765	.4 154.23
66-67 (62 Amp.) 2nd Design	1117767	.4 151.70

Cont'd.

CORVETTE 1963-67

CHEVROLET

COOLING & ENGINE, Cont'd.

UNDER HOOD ITEMS

DELCOTRON & PARTS, Cont'd.

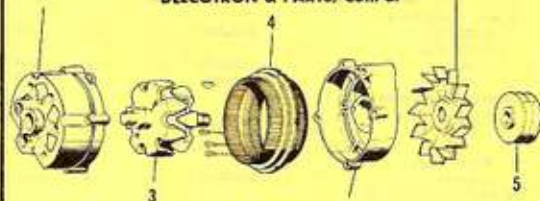

1.	Frame, Front (D. E.) exc. 62 Amp. 62 Amp. (1st Design) 62 Amp. (2nd Design)	1955917 1955492 1961866	5.25 5.95 13.00
2.	Frame, Rear (S. E.) exc. 62 Amp. 62 Amp.	809596 1955545	19.60 6.80
3.	Rotor, w/Shaft Exc. 60 Amp. 62 Amp. (1st Design) 62 Amp. (2nd Design)	1958565 1964119 1955497 1955679	25.35 22.25 53.95 65.20
4.	Stator, Field 42 Amp. 52 Amp. 60 Amp. 61 Amp. 62 Amp.	1969381 1959531 Disc. 1964122 1962025 1958822	17.85 16.70 17.85 17.85 39.95
(*Includes Items 1 thru 4.)			
5.	Pulley, Delcotron w/o A. C. 63 w/o Fan w/Fan 63-64 w/H. P. Eng., F/Inj. 64 w/o H. P. Eng. 65 w/o H. P. Eng. 65-66 w/327 H. P. Eng., F/Inj. 65-67 w/327 H. P. Eng., P. S. 66 exc. 427 Eng. * 66-67 w/427 Eng., P. S. w/A. C. 63 w/o Fan 64-65 w/327 H. P. Eng. 65-66 w/327 Eng. * 66-67 w/427 Eng., w/o P. S. 66-67 w/427 Eng., P. S. w/or w/o A. C. 65 w/396 H. P. Eng. 66 w/327 Eng. w/62 Amp. 66 w/427 Eng., P. S. 66-67 w/427 Eng. (*w/Fan.)	3792460 3830422 3829193 3871241 3871241 3871242 3829387 3909816 3871242 1949355 3846180 3909817 3846180 3883978 3829387 3909817 3871242 3829387 809594	5.75 2.96 5.55 6.25 6.25 5.55 6.05 3.49 5.85 2.97 5.55 3.38 5.55 5.55 6.05 3.38 5.85 6.05 1.87
6.	Fan, Pulley (11 Blades) Bracket, Mounting 63 w/o A. C., w/62 Amp. 63 w/A. C. 63-65 w/o A. C., exc. 396 Eng. 64-66 w/327 Eng., w/62 Amp. 65 w/or w/o A. C. 66-67 w/427 Eng., w/o P. S. 67 w/427 H. P. Eng., P. S. Support, Bracket Exc. 64-65 w/327 Eng., w/62 Amp. 67 w/427 Eng., P. S. Upper Lower Regulator, Voltage Exc. w/62 Amp. 66 w/327 H. P. Eng., w/T./Ign.	3815460 3825461 3860461 3892968 3863138 3882810 3878236 3846565 3894008 3878239 3878240 1119515 1116378 1116378	Disc. 3.65 2.97 2.51 3.16 3.59 8.35 3.74 1.03 1.69 .97 .92 17.60 35.10 35.10

Cont'd.

COOLING & ENGINE, Cont'd.

UNDER HOOD ITEMS

ENGINE



R&I Engine Assembly 63-64 65-67 exc. w/396, 427 Eng. Add w/A. C. (*Does not Incl. Evacuate & Recharge System) w/P. S. w/Fuel Injection w/Smog Device	5.6 7.6 6.3 .5 .3 .6 .4		
Balancer, Front (w/o Pulley) 63-65 w/327 Eng. 63-67 w/327 H. P. Eng., F/Inj. 65-67 w/396, 427 Eng. 63-67 w/396, 427 H. P. Eng. 66-67 w/327 Eng. 67 w/427 H. P. Eng. (#1.1 exc. w/Radiator removed .3)	3896904 3817173 3960066 3860610 3895903 3879623	# # # # # #	16.35 38.10 19.75 19.75 19.00 22.30
Pulley, Front (Use Balancer Time.) 63-66 exc. 63-65 w/327 Eng., P. S. 63-67 w/327 H. P. Eng., F/Inj. 64-66 exc. 427 Eng. 65-66 w/327 H. P. Eng., A. C., P. S. 65-66 w/396, 427 Eng., A. C. 66 w/327 Eng. 66 w/327, 427 H. P. Eng., P. S. 66-67 w/327 H. P. Eng., A. C., P. S. 67 w/327 Eng., A. C. 67 w/327 H. P. Eng., P. S. 67 w/427 H. P. Eng., P. S. 67 w/427 Eng., A. C.	3744063 3751232 3858332 3858338 3827843 3863108 3755820 3751232 3827843 3858338 3751232 3863108	4.00 3.36 3.38 3.59 4.82 6.80 1.64 2.36 3.59 3.59 3.59 2.36 2.36 6.80	
Motor Mounts Front (2) Rear 63 64-67 (#327 Eng. .4, 427 Eng. .6 exc. w/Side Exhaust .3)	3909816 3870182 3792133	.5 .4 #	16.25 2.82 2.92
Bracket, Motor Mount Front Rear, Frame Mounting Trans. Mounting (1)	3819306-5 3893570-59 3829372		4.31 57 2.26
Cover, Front Timing (w/Oil Seal) 63-67 w/327 Eng. 63-67 w/327 H. P. Eng., F/Inj. 66-67 w/396, 427 Eng.	3865639 3923290 3975941	4.3 4.3 3.7	4.51 4.61 5.35
Seal, Front Cover w/327 Eng. w/396, 427 Eng.	3966267 3860695	2.3 1.2	1.79 1.05
Gasket, Front Cover w/327 Eng. w/396, 427 Eng.	3799620 3860696	.20 .25	
Oil Pan 63-67 w/327 Eng. 63-65 w/327 H. P. Eng., F/Inj. 65-67 w/396, 427 Eng.	3820600 3956670 3877591	1.9 1.9 1.8	27.10 27.80 30.25
Gasket Pkg., Oil Pan 63-67 w/327 Eng. 65-67 w/396, 427 Eng.	3901597 3958614	1.9 1.8	3.33 3.49
Fuel Pump 63-65 w/327 Eng. 64-65 w/327 H. P. Eng., F/Inj. 65 w/396 Eng. 66 w/327 Eng. 66 w/427 Eng. 67 w/427 Eng.	5621665 6413325 6416245 6413325 6416245 6416712 6416741	Disc. 1.0 1.0 .7 1.0 .7 1.0	5.40 18.40 18.40 12.00 12.00 9.75 14.10
Oil Filter Assembly (AC-PM16) Element, Filter (AC-PF141)	5574538 5574540		11.25 3.41

Cont'd.

CHEVROLET

APRIL 1, 1972

COOLING & ENGINE, Cont'd.
UNDER HOOD ITEMS

AIR CONDITIONING

R&R Does Not Include
Evacuate & Recharge System 1.4
When the air conditioning system
has been opened due to collision
damage the receiver dehydrator
should be replaced.

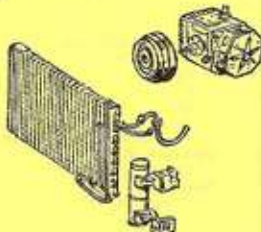

Capacity of System
Refrigerant 3 lbs. - 4 oz.

Condensator				
63	3831604 (D)	1.3	62.05	
64-65	3849326	1.3	75.30	
66-67	3891725	1.3	78.10	
Compressor				
Body Assembly				
62-66 (1st Design)	5910495	#1.7	131.15	
66 (2nd Design)	5910432	#1.7	131.15	
67	5910495	#1.7	131.15	
(Includes R&R Pulley & Bearing.)				
Head, Compressor				
Front	6550283		18.60	
Rear	6550302	1.0	18.60	
Shell Assembly	5914808		24.45	
Cylinder Assembly				
62-66 (1st Design)	5914807 O/H	3.7	27.95	
66 (2nd Design)	5914810 O/H	3.7	77.90	
67	5914809 O/H	3.7	77.90	
Shaft, w/Wobble Plate	5914705 O/H	3.7	21.20	
Seal Kit, Shaft	6599114		7.20	
Pulley, w/Bearing, Compressor				
exc. 63 H. P. Eng.	5914745	.5	47.25	
63 H. P. Eng.	5914724 Disc.	.5	43.50	
Bearing, Pulley	9073757		13.95	
Belt, Compressor				
62-67 exc.	3946065	.3	3.95	
66-67 w/327 H. P. Eng., w/o P.S.	3946065	.3	3.95	
w/427 Eng. *	1490919	.3	4.15	
66-67 w/427 H. P. Eng. ** (*w/o Smog Device) (**w/Smog Device)	9783071	.3	4.00	
Clutch Plate w/Hub	5914719	.4	14.55	
Coil w/Housing, Clutch Plate	6550835	.6	25.10	
Valves				
Pressure Relief	5914435	.2	6.25	
Expansion, Evaporator	5910613	1.6	35.30	
Suction Throttle				
62-66	5910471	#	39.05	
67	5910607	.4	28.40	
(#63-65 .2, 66 .4)				
Receiver w/Dehydrator	3153342	.5	23.15	
Evaporator Core				
63-65	3159719 Disc.	2.0	67.50	
66	3007632	3.4	69.20	
67	3003071	3.4	75.10	
Sight Glass Pkg.	3149478	.3	2.26	
Cover, Evaporator				
66	3007627	#	25.35	
67	3012645	#	25.35	
(#Included w/Core R&R.)				
Fitting, w/Muffler, Compressor	3923139		15.70	
Hose, Compressor				
Discharge * (1" I. D.)	9789795		2.26	
Suction * (1-1/8" I. D.)	9798788		2.77	
(*Per Ft., Cut to required length.)				
Case, Blower - Not Serviced Separately				
Motor, Blower	4914016	.8	28.00	

COOLING & ENGINE, Cont'd.
UNDER HOOD ITEMS

HEATER PARTS

Heater Assembly R&R 1.2

Case, Blower w/o A. C. 63-67	3156853	1.7	13.50
w/A. C.	3158361	1.7	11.95
Motor, Blower 63-67	4918686	.3	20.60



HOOD

Refinish Hood 3.0

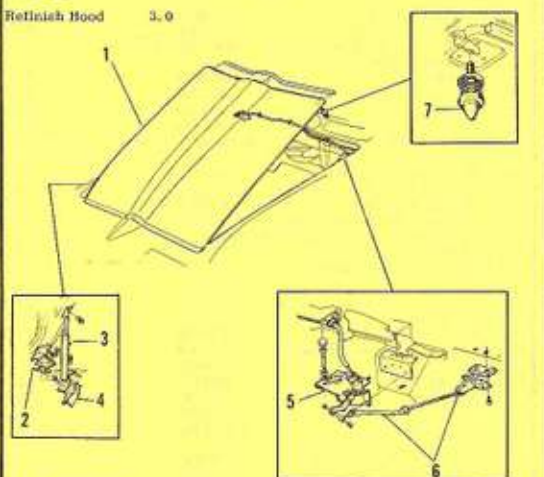

1. Panel, Hood				
63-64	3857403	1.2	121.99	
65-67 w/327 Eng.	3857463	1.2	121.99	
65-66 w/396, 427 H. P. Eng.	3874793	1.2	121.99	
67 w/427 Eng.	3910280	1.2	121.99	
Emblem, Number *				
14"	3900325	.2	.67	
16"	3900326	.2	.67	
17"	3900327	.2	.67	
(*For Front End Panel Emblem, SEE Grille Section.)				
Nameplate "Corvette"				
67 (Optional)	3873776	.2	2.41	
Ornament (Simulated Grille)				
63 Only (2)	3837260 Disc.	.2	8.00	
Grille, Air Inlet				
65-66 w/396, 427 Eng.	3868764-3	.2	2.97	
67 w/427 Eng.	3894551	.2	7.85	
Shield, Air Inlet				
65-66 w/396, 427 Eng. R/L	3878423		1.18	
2. Hinge	3797062-1	.4	2.82	
3. Support	3797079	.3	4.20	
4. Bracket, Support	3797473		.41	
5. Catch, Lock	3841438-7	.4	2.61	
6. Cable w/Bracket, Lock Release				
63-66 w/o A. C.	3820987		4.72	
w/A. C.	3541249		4.92	
67	3900251		4.25	
7. Pilot Bolt, On Hood	3782560	.2	.46	

Cont'd.

CORVETTE 1963-67

CHEVROLET

APRIL 1, 1972

FRONT FENDER

- Refinish Complete 2.0
Upper Panel 1.5
Fender Trim (exc. Item 3) includes
R&R Headlamp & Headlamp Door,
But Does Not Include Time to
customize Headlamp Opening to
fit Door.
Fender Items 1 & 2 time includes
R&R Bumper on One Side. Add to
R&R opposite Side .5
R&R Items 1, 2 & 3 18.0

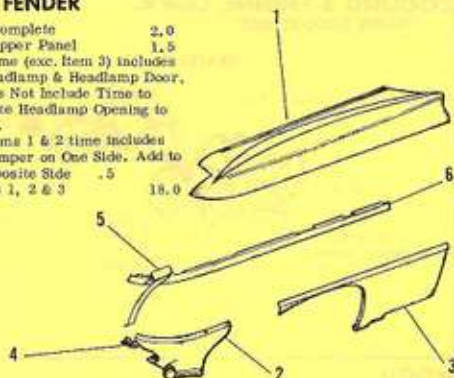

1. Panel, Upper Side	3848066-7	12.4	74.55
2. Panel, Front Lower (#6.5 exc. w/Upper Panel removed 3.9)	3831930-29	#	22.25
3. Panel, Rear Lower			
63-64 H.H.	3833358	#	22.65
L.H.	3833357	#	24.10
65-66	3857526-5	#	23.15
67	3897404-3	#	21.85
(#5.9 exc. w/Upper Side (Item 1) removed 4.9)			
Bonding Strip			
4. Lower Front to Grille	3797478-7		1.95
5. Lower Front to Lower Rear	3797480-79		3.18
6. Upper to Lower	3849214-3		6.95
Upper to Windshield Lower	3842058-7		5.02
Reinforcement, Upper Side Panel			
63-64	3833278-7		1.08
Nameplate "Fuel Injection"			
63-64	3818675	.2	2.67
65	3857572	.2	2.67
Emblem, Side			
63 "Crossed Flags"	3752000	.2	1.33
63-66 "V-Crossed Flags"	3872930	.2	1.85
65 "396"	3872997	.2	2.96
66-67 "427"	3876425	.2	2.41
Skirt, Inner	R.H. 3908198 L.H. 3886893	#	41.50
	(#R.H. 1.8, L.H. 2.2 w/Fender removed.)		
Filler, Skirt			
w/A.C. (L.H. Only)	3833397		10.65
Shield, Skirt Splash	3797276-5		3.49
Shield, Skirt Dust			
63-67 (2)	3908199		1.08
Reinforcement, Skirt	3797424-3		.67
Flange, Skirt (63 Only)			
Front	3824414-3 Disc.		1.10
Rear	3824690-89 Disc.		1.06

WHEEL

Refinish .5



Wheel			
w/o Knock-Off Wheels			
63-64	3838080	.3	19.00
65-66	3869156	.3	17.35
w/Knock-Off Wheels			
63-65 (Vaned Aluminum)	3868768	.3	85.75
66	3877236	.3	105.15
Aluminum Wheels			
67	3910730	.3	105.15
w/Disc Brakes			
67	3901698	.3	19.25
Adapter, Knock-Off Wheels			
63-66	3847764-3		27.15
Hub Cap			
67 w/Disc Brakes	3901712		4.92

Con'd.

WHEEL, Con'd.

Cover, Wheel			
63 (Alum.) w/Ribs & Orna.	3830638		20.15
63 (Chrome)	3843538		21.40
64 (Chrome)	3849557		20.15
64 (Silver)	3862137	Disc.	17.75
65	3904521		23.65
66 w/Ornament	3888813		18.20
67 w/Aluminum Wheels	3910731		22.75
Ornament, Cover			
63	3964518		5.25
64	3843387		4.51
65	3904520		6.60
66	3964515		5.25
67 w/Aluminum Wheels	3908161		4.36
Ornament, Hub Cap			
67 w/Disc Brakes	3901715		2.41
Ring, Trim			
67 exc. Aluminum	9796696		12.50

FRONT SUSPENSION

- Align Complete 1.5
Set Toe-In .5
O/H (Includes Align) .5
One Side 4.9
Both Sides 8.1
R&R Does Not Include Alignment.
O/H Includes Alignment.

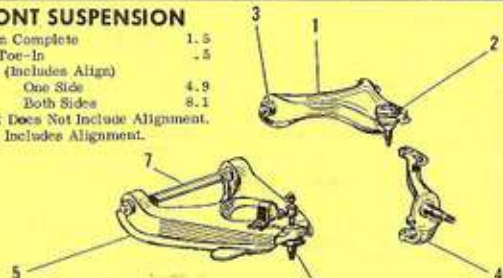

Drum, Front Less Hub

63-64 w/Metallic Lining	3872984	.4	19.75
63-64 Fan Cooled	3843900	.4	20.75
63-65 w/o Metallic Lining	3872326	.4	19.75
Disc, Front w/Hub			
65-67	3998278	1.8	51.00
Hub, Front w/Bolts			
63-65 w/o Disc Brakes	3812712	.5	9.75
Hub, Front w/Disc - SEE Disc w/Hub Above			
Fan, Drum Cooling			
63-64	3821105 Disc.		3.60
Bearing, Front Wheel			
Inner	7450620	#1.1	3.60
Outer	7450627	#1.1	2.80
(Includes R&R Inner &/or Outer Bearings & Caps.)			
Seal, Bearing Oil	3876192	#	.62
(#Seal &/or Bearings 1.1)			
Backing Plate, Brake			
63-64 w/o H.P. Eng.	3858826-5	1.2	6.30
w/H.P. Eng.	3841826-7 Disc.	1.2	31.95
65	3858826-5	1.2	6.30
Shield, Disc Splash			
63-67	3964118-7		2.21
Support, Caliper Adapter Brki.	3852784-3		7.30
Housing, Caliper Less Shoes			
w/o H/Duty Brakes			
Inner	5467290-89	#	30.80
65-66	5401968-7	#	37.45
67	5465253	#	25.40
Outer	5452274	#	35.00
w/Heavy Duty Brakes			
Inner	5467290-89	#	30.80
67	5453158-8	#	47.05
Outer	5452937-6	#	N.A.
67 (2nd Design) (3)5487263		#	45.15
(#63-66 1.9 includes Bleed, 67 1.6 includes Bleed.)			
Hose, Brake			
w/o H/Duty Brakes	3898231	#	6.70
w/Heavy Duty Brakes	3910724	#	2.87
(#One .4, each additional .2, includes Bleed.)			

Con'd.

APRIL 1, 1972

CHEVROLET

CORVETTE 1963-67

FRONT SUSPENSION, Cont'd.

Spring, Front Coil			
w/Standard Suspension			
63-64 w/o H. P. Eng. *	3832684	1.6	12.80
w/A. C.	3832684	1.6	12.80
64-67 w/o H. P. Eng. **	3851100	1.6	15.40
66-67 w/427 Eng. exc.	3888250	1.6	15.15
w/427 H. P. Eng.			
w/A. C.	3888251	1.6	16.15
w/Heavy Duty Suspension			
63-67	3832518	1.6	16.05
	(#1st Design; **2nd Design)		
Shock Absorber			
Standard	3192972	.4	13.25
Heavy Duty	3192091	.4	13.25
Grommet, Shock			
63-64	381957	.4	.10
65-67	3790341	.4	.15
1. Arm, Upper Control (Less Shaft)			
w/Ball Joint	3832350-49	.9	21.70
2. Ball Joint Plg. (2)	3885827	.8	11.40
3. Shaft Plg., Upper Arm (2)	3843244	.9	9.10
Bushing, Shaft (4)	3711826	.7	1.18
4. Steering Knuckle (Spindle)			
63-64	3828580	1.2	29.40
65-67	3864023	1.2	28.20
	#1.2 exc. w/Disc Brakes 1.7)		
Arm, Steering Knuckle	3829498-7	1.0	9.55
	(#.6 exc. w/Disc Brakes 1.5)		
5. Arm, Lower Control (Less Shaft)			
w/Ball Joint	3849284-3	2.0	24.10
6. Ball Joint Plg.			
63-67	3886422	.9	11.95
7. Shaft Plg., Lower Arm (2)	3749296	2.3	10.15
Bushing, Shaft (4)	3714368	2.3	.97
Shaft, Stabilizer			
w/Standard Suspension			
63-67 w/327 Eng.	3831971	.8	7.35
65-67 w/396, 427 Eng.	3871318	.8	7.40
w/Heavy Duty Suspension			
63-67	3831972	.8	7.70
Bushing, Stabilizer Shaft			
w/Standard Suspension			
63-67 w/327 Eng.	3817673	.4	.50
65-67 w/396, 427 Eng.	3871323	.4	.67
w/Heavy Duty Suspension			
63-67	3826826	.4	.62
Link, Stabilizer Shaft			
63-67 (Bolt Type) (2)	3817576	.5	.46
Bushing, Shaft Link			
63-66	381957	.5	.10
Link Plg., w/Bushing			
65-67 w/396, 427 Eng.	3872452	.5	1.55

FRAME & UNDERBODY

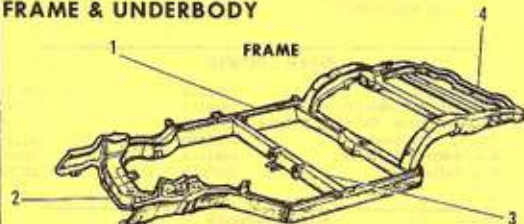

1. Frame Assembly			
63-67	3900200	# 30.0	217.85
	(#Includes time to support Body to avoid damage to plastic panels.)		
2. Crossmember, Front - Not Serviced Separately			
3. Crossmember, Trans. Support			
	3900266		22.85
4. Crossmember, Rear	3828035	# 2.5	9.75
	(#w/Bolted parts removed.)		

Cont'd.

FRAME & UNDERBODY, Cont'd.

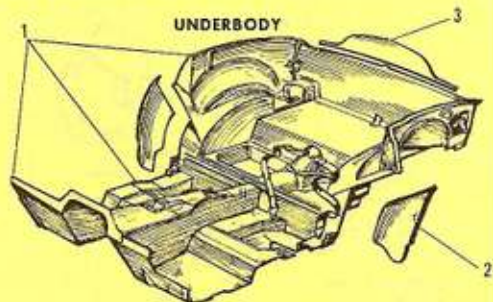

1. Panel, Underbody			
63-66	3897384		224.50
67	3897384		224.50
Panel, Lock Pillar Filler To Wheelhouse	3797380-79		7.85
2. Panel, Wheelhouse Filler			
63-67	3908104-3		22.45
3. Panel, Rear Closing	3797228		7.85
Panel, Rear Lower Filler			
63	3797190		37.45
64-65	3877059		35.05
66-67 w/o Side Mounted Exh.	3874799		20.20
65-67 w/Side Mounted Exh.	3863752		26.75
Cover, Tunnel *			
63-64 (Black)	3853662	Disc.	13.10
65-66 exc. (Black)	3863075	Disc.	13.10
Leather (Black)	3863067	Disc.	22.40
67 (Black)	3894541		8.70

(*For Colors Not Listed - Call Local Dealer. Trim No. needed.)

STEERING LINKAGE

R&R Does Not Include
Adjust Toe-In .5

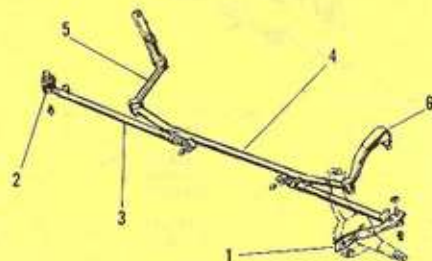

1. Arm, Steering Knuckle			
	3829498-7	#	9.55
	(#.6 exc. w/Disc Brakes 1.5)		
2. End, Tie Rod			
R. H. Thread	3826814	#	4.82
L. H. Thread	3826896	#	4.82
	(#R&R one .3, Both .5)		
3. Sleeves, Adjusting	(2) 3820816		4.77
4. Drag Link (Relay Rod)			
w/o P. S.	3905512	.6	22.20
w/P. S.	3952707	.9	16.15
5. Idler Arm Assy., w/Support	3779184	.6	5.80
	(*Includes Bushing.)		
6. Arm, Pitman			
w/o P. S.	3829451	.8	6.90
w/P. S.	3741388	.8	6.55
Shock Absorber, Steering Bracket, Shock	3178100	.6	13.25
	3830242		1.44

CORVETTE 1963-67

CHEVROLET

APRIL 1, 1972

STEERING COLUMN

WHEEL & TRIM



Steering Wheel				
63-66 Plastic - Walnut Grained	9740683		.3	61.00
64-66 Wood	9742156	Disc.	.3	72.45
67 Plastic - Walnut Grained	9748399		.3	58.15
(*For Colors Not Listed - Call Local Dealer.)				
Hub, Steering Wheel				
63-66 w/o Tel. Wheel *	3925362			10.05
65-66 w/Tel. Wheel *	3863902			5.35
67	3923697			7.50
Cap, Horn Blowing				
63-64	769747		.2	5.25
65-66 w/o Tel. Wheel *	3899365		.2	4.66
67 w/Tel. Wheel *	3883227		.2	4.56
67	3899365		.2	4.66
(*Telescopic Wheel.)				

DIRECTIONAL SIGNAL & PARTS

Switch, Signal				
63	3524116		.6	1.79
64-66 w/o Tel. Wheel	910821		.6	10.85
65-66 w/Tel. Wheel	5696681		.6	18.80
67 (Delco-Ring)	7800433		.7	9.60
67 (Boyno)	5698320		.7	15.99
Lever, Signal Switch				
63 w/Knob	3783459			1.33
64-67 w/o Knob	3854303			.41
67 w/o Knob	3999550			.56

COLUMN - STANDARD



Column Assembly				
63-66	Not Serviced - Use Components			
67	7803156		.7	65.40
Jacket, Column				
63	3824102	Disc.	.7	6.60
64-66	3866469		.7	3.25
67	7802118			24.25
Shaft, Steering				
63-66	5690810		1.1	6.85
67	5699851		1.1	20.00
Coupling, Shaft Lower				
63-66	5690809		.7	25.85
67 (w/Flange)	5699250	Disc.	.7	8.50
Flange, Shaft				
Upper				
63-66	5690811			6.75
67	7807052			7.60
Lower				
63-66	5691327			13.20
67	Not Serviced - SEE Coupling Above			
Flange, Jacket Upper				
67 Only	7800569			2.77
Bearing, Column				
Jacket Upper				
63 (w/Horn Wire)	5672608		.4	2.82
64-67	5955201		.4	.77
Shaft Lower				
63-66	7802845		.4	2.05
67	7806142		.4	1.33

Cont'd.

STEERING COLUMN, Cont'd.

COLUMN - TELESCOPIC

Column Assembly				
63-66	Not Serviced - Use Components			
67	7803280		.7	121.45
Jacket, Column				
65-66 (Inner & Outer)	5696386		1.3	21.20
67	7803024		1.3	55.00
Cover, Jacket (67 Only)				
Upper	3901944			.62
Lower	3901945			.62
Shaft, Steering Upper				
65-66	5694176		1.3	37.60
67	7803004		1.3	49.45
Coupling, Shaft Lower				
65-66	5692974		.7	16.20
67 (w/Flange)	5699250	Disc.	.7	8.50
Flange, Shaft				
Upper				
65-66	5690811			8.75
67	7807052			7.60
Lower				
65-66	5691327			13.20
67	Not Serviced - SEE Coupling Above			
Bearing, Column				
Jacket, Upper				
65-67	5955201		.5	.77
Shaft Upper				
65-66 (2)	5674684			1.79
67	7801324			2.15

STEERING GEAR

GEAR - MANUAL

	Adj.	R&R	*O/H
63-64	.9	1.3	3.2
65-67	.9	.8	2.7

(*Includes R&I Assy.)



Gear Assembly				
63-64	7807927			95.45
65-67	5677650			22.90
Nut, Gear Ball	5677095			8.75
Bearing, Worm Thrust (2)	5666683			.68
Cap, Thrust Bearing (2)	5666683			1.27
Shaft, Pitman (w/Gear)	7812838			43.60
Bushing, Pitman Shaft	266316			1.59
Adjuster, Worm Gear	5677642			5.02
Housing, Gear (w/Bushing)	5677646			27.90
Cover, Gear Housing				
Side w/Bushing	7806748			6.90

GEAR - POWER

Cylinder, Gear	5691112		.5	32.45
Bracket, Cylinder (To Frame)	3832131			2.41
Reinforcement, Cylinder Bracket	3832132			1.18
Valve, w/Adapter	5691955		.9	41.30
Kit, Adapter & Sleeve	5691151			10.70
Kit, Valve	5691959	O/H	1.3	35.75

O/H Pump 1.8
w/427 Eng. 2.3

PUMP - POWER

Pump, w/o Pulley				
63-64	5692840		.8	61.50
65-67	7808286		#	61.65
(*.5 Exc. w/427 Eng. 1.1)				
Housing, Pump				
63	5689435			19.35
64	5692823	Disc.		18.90
65-66	5692883			22.90
67	7807934			25.65



Cont'd.

APRIL 1, 1972

CHEVROLET

CORVETTE 1963-67

STEERING GEAR, Cont'd.

PUMP - POWER, Cont'd.

Vane Kit, Pump	5688047		8.60
Rotor Kit, Pump	5690858		26.20
Shaft, Pump Drive			
63-66	7807816		7.80
67	7810333		8.45
Seal, Pump Shaft			
63-66	5688020		1.33
67	7808195		1.18
Valve, Pump Control	5699397	.9	5.55
Filter, Pump	5689351		3.28
Element, Pump Filter	5689352		1.85
Reservoir, Pump			
63	5691196	.9	11.30
64-67	5692845	.9	9.35
Cap, Reservoir Filler	7803820		2.56
Pulley, Pump			
63-67 w/327 Eng.	3770509	.8	3.74
65-67 w/327 H. P. Eng.			
w/o A. C.	3878243	.8	8.95
w/A. C.	3868892	.8	3.43
65-67 w/396, 427 Eng.	3878243	.8	8.95
Belt, Pump			
63-65 w/327 Eng. (1st Design)	3837810	†	4.56
65-67 w/327 Eng. (2nd Design)	3927158	†	2.92
65-67 w/396, 427 Eng.			
w/o A. C.	3946009	†	2.83
w/A. C.	1374979	†	3.13
66-67 w/327 H. P. Eng.			
w/o A. C.	1374979	†	3.13
w/A. C.	3927158	†	2.92
66-67 w/427 H. P. Eng., A. C.	3946009	†	2.83
(#One .2, each additional .1)			
Hose, Pump			
Inlet			
w/327 Eng.	3826277	† 4	5.25
w/396, 427 Eng.	3878886	† 4	7.05
Outlet	3826278	† 4	2.56
(#Both .5)			
Bracket, Pump Mounting			
63-64	3786870	.4	1.64
65-66 w/o H. P. Eng.	3946002	.4	4.77
w/H. P. Eng.	3928493	.4	2.50
Support, Pump Mounting			
63	3786871		1.08
64-65 (1st Design)	3805138		1.03
65-67 (2nd Design)	3928493		2.56
Brace, Pump Mounting			
65-67 w/396, 427 Eng.	3946000		4.40

EXHAUST

Manifold, Exhaust			
w/327 Eng.			
w/o H. P. Eng.			
63-65	R. H. 3817806	† 1.1	21.15
66-67*	R. H. 3932461	† 1.1	23.30
63	L. H. 3749965	.8	16.30
64-67**	L. H. 3846559	.8	16.05
66-67*	L. H. 3872765	.8	18.40
w/H. P. Eng.			
63-65 w/o P/Glide	R. H. 3814970	† 1.1	20.60
64-65 w/P/Glide	R. H. 3817806	† 1.1	21.15
66-67*	R. H. 3932461	† 1.1	23.30
63	L. H. 3797901	.8	20.60
63-65	L. H. 3814970	.8	20.60
64-65 w/o P/Glide	L. H. 3846563	.8	19.60
64-65 w/P/Glide	L. H. 3846559	.8	16.05
66-67*	L. H. 3872765	.8	18.40
67**	L. H. 3846559	.8	16.05
w/396 Eng.			
w/H. P. Eng.			
65	R. H. 3879898	† 1.3	36.20
	L. H. 3868833	1.4	29.85
w/427 Eng.			
w/o w/o H. P. Eng.			
66-67*	R. H. 3880834	† .5	30.60
66-67*	L. H. 3880833	.5	30.60
66-67**	L. H. 3880833	.5	29.85

(*w/Smog Device; **w/o Smog Device)
 (†w/A.C., Add .5)

EXHAUST, Cont'd.



Pipe, Exhaust (exc. Side Mounted) *

Front			
w/o H. P. Eng.			
63			
64-65 w/327 Eng.		3822582-1	.5 6.85
66-67 w/327 Eng.		3849866-5	.5 7.25
w/o P/Glide			
65-67 w/396, 427 Eng.		3877210-09	.5 10.10
66-67 w/427 Eng., P/Glide		3869584-3	.5 7.25
		3869584-3	.5 8.95
w/H. P. Eng.			
63		3880402-1	.5 8.15
64-65 w/327 Eng.		3819566-5	.5 10.10
w/o P/Glide			
65-67 w/327 Eng.		3849862-1	.5 9.10
65-67 w/396, 427 Eng.		3849866-5	.5 7.25
66-67 w/427 Eng., P/Glide		3877210-09	.5 10.10
		3869584-3	.5 8.85
66-67 w/427 Eng., P/Glide		3880402-1	.5 8.15
67 w/427 H. P. Eng.		3899618-7	.6 190.35
Rear			
w/o H. P. Eng.			
63	R. H. 3830628	†	16.20
	L. H. 3830627	†	15.50
64-65		3846534-3	† 15.50
65-66 w/327 Eng.		3863498-7	† 12.30
66-67 w/327 Eng., P/Glide		3846534-3	† 15.50
w/H. P. Eng.			
63	R. H. 3830632	†	17.36
	L. H. 3830631	†	16.95
64-66 w/o P/Glide		3863498-7	† 12.30
64-67 w/P/Glide		3846534-3	† 15.50
(*For Side Mounted Exhaust, SEE Muffler.) (†.2 w/Front Pipe removed.)			
Extension, Exhaust Pipe to Muffler			
65 w/Side Mounted Exh.		3823539	1.27
66-67 w/427 Eng.		3823539	1.27
Support, Exhaust Pipe Front			
63 w/o P/Glide		3828188	6.20
w/P/Glide		3828187	5.30
Muffler			
Exc. Side Mounted Exhaust			
63-65 exc. H. P. Eng.	R. H. 3846532	.6	33.75
	L. H. 3846531	.6	33.75
64-65 H. P. Eng.			
w/o P/Glide	R. H. 3943388	.6	33.75
	L. H. 3943385	.6	33.75
64-66 H. P. Eng.			
w/P/Glide	R. H. 3846532	.6	33.75
	L. H. 3846531	.6	33.75
66-67 w/o P/Glide	R. H. 3943388	.6	33.75
	L. H. 3943385	.6	33.75
67 w/P/Glide	R. H. 3846532	.6	33.75
	L. H. 3846531	.6	33.75
Side Mounted Exhaust (w/Pipes) *			
65 w/327 H. P. Eng.		3872972-1	40.95
65-67 w/396, 427 Eng.		3872970-69	31.60
66-67 w/327 Eng.		3877216-5	48.70
(*For Cover, SEE Rocker Panel.)			
Bracket, Muffler			
63		3827498-7	.51
64-67 exc. Side Mounted Exh.		3849776-5	1.18
Insulator, Exhaust & T/Pipe			
w/Side Mounted Exhaust (4)		3863849	.77
Tail Pipe			
exc. Side Mounted Exhaust		3819573	.3 10.20
Bozell, Tail Pipe			
63		3826942-1	5.85
64-65		3850506-5	6.20
66-67 exc. Side Mounted Exh.		3892226-5	4.56

Cont'd.

CORVETTE 1963-67

CHEVROLET

APRIL 1, 1972

WINDSHIELD



Glass, Windshield	(Car Mfr.)		(Glass Co.)	
63-65	C 3878865	2.2	Use	NAGS W636
	T 3878870		Glass	
66-67	C 3878868	2.2	Price	NAGS W636
	T 3878870		List	
Weatherstrip, Glass				
Sport Coupe		3844049		7.60
Conv.		3844047		7.50
Moulding, Reveal (w/o Clips)				
Sport Coupe				
63	Upper	3823435	.9	4.66
	Side	3823430-29	.2	9.10
	Lower	3823440	.4	6.40
64-67	Upper	3841255	.9	5.15
	Corner	3859044		1.74
	Lower	3841252-1	.4	4.51
Conv.				
63-67	Upper	3823439	.9	6.10
	Side	3823444-3	.2	9.95
	Lower	3841254	.4	4.92
Moulding, Garnish				
Sport Coupe				
64-67	Upper	3841612	.3	4.92
63-67	Side	3823252-7	.2	8.60
63-67	Lower	3823437		2.00
Conv.				
64-67	Upper	3831572	.3	4.92
63-67	Side	3823442-1	.2	8.60
63-67	Lower	3823437		2.00
Mirror, Inside Rear View (Chrome)				
		916177	.2	6.65
Support, Inside Mirror				
63-67		3812412	.2	2.26
Sun Visor, Inside (Black) *				
63-64 exc.		3830490-89	Disc.	.2 7.50
64	Sport Cpe.	3849341		.2 7.70
65-66	Sport Cpe.	3861458	Disc.	.2 7.70
	Conv.	3889444-3	Disc.	.2 7.50
67	Sport Cpe.	3904915		.2 7.70
	Conv.	3904902-1		.2 7.70
(*For Colors Not Listed, Call Local Dealer.)				
Support, Sun Visor				
Inner & Outer	(4)	3830488		.67

WIPER & WASHER PARTS

Blade, Wiper				
63-65	(Trico-14-7/8")	3941969		2.92
63-65	(Asco-15-5/32")	3779741		3.18
65-67	(Asco-15")	3888296		3.33
66	(Trico-14-7/8", 1st Design)	3899508		3.45
66-67	(Trico-14-7/8", 2nd Design)	3899508		3.49
Insert, Wiper Blade				
63-66	(14-7/8")	3819074		3.26
64	(15-5/32")	3821753		3.26
Arm, Wiper Blade				
63-65		3829262-1		3.74
66-67		3915862-1		3.74
Trans. (Pivot), Wiper				
	R. H.	4911516	.5	11.10
	L. H.	4911517	.5	11.80
Motor, Wiper		4909107	1.1	47.20
Jar, Washer (w/o A. C.)		3940983	.2	1.58
Cap, Washer Jar		3798372		.35
Reservoir, Washer (w/A. C.)		3903407		1.85
Pump, Washer		4509111		16.60
Valve, Pump		4914356		2.75
Nozzle, Washer Spray	(2)	3824042		1.64

ROCK and DASH

Retinish Top Panel	1.3		
Hinge Pillar	1.0		
Instrument Panel	1.5		
Inner Panel or Pillar Time is w/Outer Panels removed.			
1. Panel, Cowl Upper	3846460	# 15.0	44.40
(Pw/Windshield removed.)			
Panel, Cowl Upper Repair 63 Only (Plastic)	3772743		(D) 40.55
2. Grille, Cowl Air Intake	3797078-7	.2	6.05
Roading Strip, to Fender	3842058-7		5.02
Panel, Cowl & Dash (Plastic)	3897419		63.05
Panel, Cowl Center			
63-65	3797150	Disc.	17.30
Panel, Cowl Side			
63-64	3797164-3	Disc.	6.80
65-66	3857528-7	Disc.	6.75
67	3897402-1		6.75
3. Pillar Assembly, Front Hinge			
63-67	R. H.	3865885	5.0 18.25
63-66	L. H.	3910119	5.0 18.25
67	L. H.	3910119	5.0 18.25
Pillar, Front Hinge *		3797106-5	3.0 13.20
Brace, Pillar to Floor *			
63-67	R. H.	3866416	3.13
63-67	L. H.	3829297	3.07
(*SEE Body Metal Frame for Illustration.)			
4. Panel, Instrument			
63-67 (Paint as required)	3894579		22.15
Crash Pad, Instrument Panel (Black) *			
5. Right			
63-64	3854754	1.0 (D)	33.50
65-66	3861796	1.0	36.40
67	3894582	1.0	38.80
6. Left	3861795	1.8	32.20
(*For Colors Not Listed, Call Local Dealer.)			
7. Insert, Assist Hold			
Door, Glove Box			
63-65	3945006	.3	20.05
66-67	3874599	.3	20.05

ROCKER PANEL

Retinish	1.0		
Reinf. Time is w/Outer Panel rem.			
1. Panel, Sill Outer			
63-66	R. H.	3899336	#4.2 18.50
	L. H.	3899335	#4.2 18.50
67		3899336-5	#4.2 18.50
Reinforcement, Sill Panel *			
		3868744-3	3.5 8.20
(*SEE Body Metal Frame for Illustration.)			
(Pw/Quarter Panel removed 2.6)			
2. Moulding, Outer Side			
w/o Side Mounted Exhaust			
63		3834713	.4 19.75
64		3849594	.4 24.15
65		3859798	.4 14.75
66		3933947	.4 14.40
67		3933948	.4 16.10
w/Side Mounted Exhaust			
63-67		3878902	Disc. .4 13.35
Cover, Exh. Pipe Heat Shield *		3872284-3	82.25
Sill Plate, Door Opening			
63-66		3707459	.3 6.90
67		3894542	.3 6.45
*w/Side Mounted Exhaust			

APRIL 1, 1972

CHEVROLET

CORVETTE 1963-67

SEAT

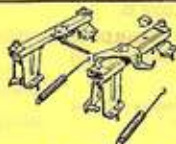

Adjuster, Seat	Not Serviced Separately - SEE Frame Below		
63-66	R. H.	3892248	.5 10.45
67	L. H.	3892247	.5 6.13
Frame, Seat Lower (w/Springs)			(D) 30.60
63 (w/Adjusters)		3833200	40.30
64-66 (w/Adjusters)		3866415	19.50
67		3892021	
Seat Belt (Black) *			
63-67		3855692	.3 8.70
Retractor Pkg., Seat Belt		956065	(D)N. L.
Harness Unit, Shoulder (Complete)			
Black *		3922046	.5 29.45
Harness Strap, Shoulder			
Black *		3855698	.3 13.95

(*For Colors Not Listed, Call Local Dealer.)

FRONT DOOR

Refinish Coupe	2.5
Conv.	2.0
R&L Door Assembly w/Elec. Lifts	.9
R&L Trim Panel	.4

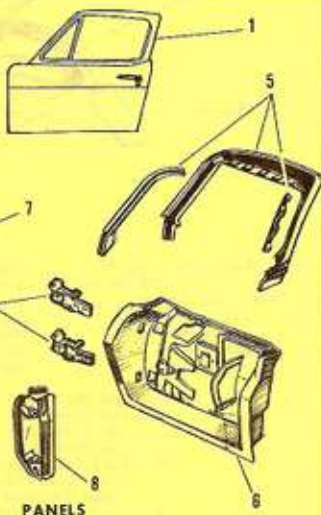

PANELS

1. Door Shell				
Sport Coupe				
63		3830736-5 Disc.	# 7.0	126.80
64-67		3912056-5	# 7.0	149.40
Conv.				
63-67		3912052-1	# 5.0	95.75
		(#Including Re-work Door to Fit Properly Aligned Door Aperture)		
Panel, Outer				
Upper				
63		3840780-79	# 3.3 (D)	8.45
64-66		Not Serviced Separately - Use Item 4 (#w/Lower Panel Removed 1.5)		
Lower				
Sport Coupe				
63-64	R. H.	3797046 Disc.	6.0	31.75
	L. H.	3839611	6.0	32.55
Conv.		3903598-7	5.4	32.53

FRONT DOOR, Cont'd.

PANELS, Cont'd.

4. Panel Assembly, Outer*				
64-67**		3854680-79	8.0	31.75
		(**Including Item 3)		
		(**When Installing on 1964 Models, Call Dealer for Additional Parts Needed to Complete Installation)		
5. Panel, Inner				
Upper				
63		3830738-7 Disc.	5.1	43.80
64-67		Not Serviced Separately - Use Shell Assy.		
6. Lower				
Sport Coupe				
63	R. H.	3680194	# 2.5	44.90
	L. H.	3880193	# 2.5	44.90
64-66	R. H.	3880194	# 2.5	44.90
	L. H.	3830193	# 2.5	44.90
67		N.A.	# 2.5	43.80
Conv.				
63-64		3797016-5 Disc.	# 2.5	43.80
65-66		3880192-3863081	# 2.5	43.80
67		3903598-7	# 2.5	32.55
		(#Includes Transfer Parts & Bonding)		
Bonding Strip, Door				
Upper Panel				
Sport Coupe		3848418-7		12.60
Lower Panel Front				
Sport Coupe				
64-66		3872118-7		3.18
Reinforcement				
Inner Upper Panel				
64-66 Sport Coupe		3851554-3		52.20
8. Reinforcement				
Door Hinge	R. H.	3880076		15.20
	L. H.	3880075		14.75
9. Hinge, Door (4)		3757171	#1.3	11.85
		(#Both 1.7)		

HARDWARE

Lock, Door				
63-66	R. H.	9705190	.7	12.75
	L. H.	9705191	.7	12.75
67		9709406-7	.7	11.45
Striker Plate		4885740-1	.2	4.61
Cylinder Unit (Uncoated)				
63-66		3775427	.9	1.79
67		3901066	.9	1.90
Handle, Outside (w/o Button)				
63-64		9702886-7	.6	5.02
65-67		5719142-3	.6	5.02
Push Button, Handle (w/Shaft)				
63-64 (1st Design)		4307966		1.33
64-67 (2nd Design)		5714778		1.13
Handle, Inside				
63-64		3823507	.2	1.54
65-67		3863680	.2	1.54
Knob, Lock Inside				
63		3829456	.2	2.67
64-67		3846934	.2	2.67
Weatherstrip, Door Opening				
Sport Coupe				
On Door		3829884-3	.5	8.15
On Front Reinforcement		3832114-3		6.95
On Hinge Pillar	R. H.	3899382		2.26
	L. H.	3899381		2.26
Auxiliary				
Conv.		3829302-1		.59
On Door		3826950-49		4.41
On Hinge Pillar				
63-67		3899384-3		15.55
Auxiliary		3829302-1		.59
Mirror, Outside				
Standard	R. H.	957025	Disc.	.3 4.50
	L. H.	3840784		.3 9.75

Cont'd.

Cont'd.

CORVETTE 1963-67

CHEVROLET

APRIL 1, 1972

FRONT DOOR, Cont'd.

VENT GLASS & PARTS					
		(Car Mfr.)		(Glass Co.)	
Glass, Vent					
Sport Coupe	C	3797044-3	.5	Use	NAGS V3178-7
	T	3840062-1		Glass	
Conv.	C	3797042-1	.5	Price	NAGS V3174-3
	T	3840064-3		List	
Ventilator Assembly					
Less Glass					
Sport Coupe		3843924-3	1.5	45.45	
Conv.		3843926-5	1.5	66.90	
Weatherstrip, Vent					
Front Sport Coupe		3841624-3	1.7	3.90	
Conv.		3823308-7	1.7	4.46	
Rear		3823310-09		.82	
Channel, Vent Sash					
Sport Coupe		3823902-1	2.0	10.95	
Conv.		3823904-3	2.0	13.20	
Channel, Vent Division					
Sport Coupe		3824746-5	1.8	3.90	
Conv.		3823312-1	1.8	3.90	
Weatherstrip, Vent Chl. Rr.					
Sport Coupe		3824642-1		1.64	
Regulator, Vent					
Sport Coupe					
63-64		3824606-5	.7	6.30	
65-67	T	9704690-1	.7	6.30	
Conv.		9704690-1	.7	6.30	
Handle, Vent Regulator					
1963-64		4775786	.2	3.28	
65-66		4468653	.2	3.28	
67 (Black)*		7650651		3.49	

(*For Colors not Listed, Call Local Dealer)

DOOR GLASS & PARTS

DOOR GLASS & PARTS					
		(Car Mfr.)		(Glass Co.)	
Glass, Window					
Sport Coupe					
63-64	C	3863862-1	1.0	Use	NAGS D3180-79
65-67	C	3863862-1	1.0		NAGS D3180-79
63-67	T	3863866-5		Glass	
Conv.					
63-67	C	3863864-3	1.0	Price	NAGS D3176-5
63-64	T	3863868 R.H.		List	
65-67	T	3863868 R.H.		List	
63-67	T	3863867 L.H.		List	
Channel, Lower Sash					
Sport Coupe					
63 (1st Design)		3833362-1		4.10	
63-67 (2nd Design)		3840590-69		5.55	
Conv.		3833288-7		4.66	
Channel, Glass Run					
Front 63-67*		3831888-7		#	2.72
Upper 63		3837662-1		Disc.	# 3.35
64-67		3888934-3		#	3.90
Rear					
Sport Coupe					
63 (1st Design)		3833308-7		#	2.36
63-67 (2nd Design)		3840596-5		#	2.26
Conv.		3833308-7		#	2.36

(*Cut 20" from Beveled End)
(#.9 exc. w/Glass Removed .2)

Seal, Glass					
Inner Upper					
Sport Coupe					
64-67		3840586-5		1.08	
Inner					
Sport Coupe		3826872-1		1.44	
Conv.					
63-66		3826874-3		1.54	
67		3903556-5		1.54	
Outer					
Sport Coupe		3866450-79		3.33	
Conv.		3826870-69		2.97	
Regulator, Window					
Manual		3797292-1	1.5	10.90	
Electric (Less Motor)		3825676-5	1.6	13.00	
Motor, Window Regulator		5045589-90	.4	37.50	
Handle, Window Regulator					
63-64		4753531		2.97	
65-66		4468651		2.97	
67 (White)*		7689666		3.64	

(*For Colors not listed, Call Local Dealer)

FRONT DOOR, Cont'd.

MOULDINGS & TRIM			
Mldg., Vent Division (w/o Clips)			
Inner		3824724-3	3.54
Outer		3824726-5	3.54
Mldg., Reveal Front (w/o Clips)			
63 Sport Coupe		3822512-1	2.26

ROOF

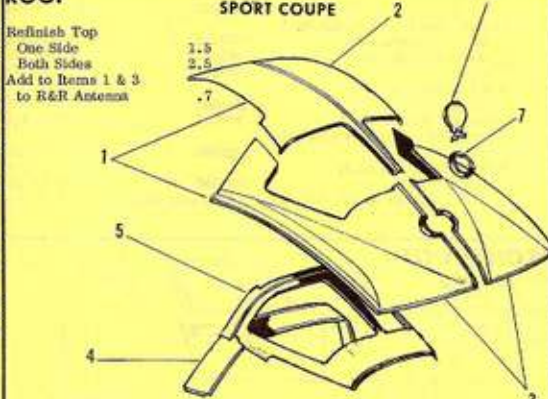

1. Panel Assembly, Outer*	3874724	22.7	157.15
(*Includes Items 2 & 3)			
Panel, Outer Repair			
2. Front 63	3830257	Disc.	16.0
64-67	3846459		11.3
3. Rear 63	3830256-5	Disc.	# 71.20
64-67	3888210-09		# 60.05
(#R&R: 1963 One Side 14.5, Both Sides 25.5 1964-67 One Side 13.6, Both Sides 24.2 Note: Cut Left or Right off Center to Avoid Gas Filler Hing & Center Compound Curve)			
4. Panel, Inner Trim (Plastic)	3846951		16.00
5. Frame, Back Window Inner (Plastic)			
63	3797319		(D)29.10
64-65	3855625	Disc.	24.40
66-67	3877255		24.30
6. Fuel Door	3874528		.3
7. Bezel, Fuel Door Opening			10.80
63	3839710		.2
64-67	3847856		.2
Housing, Filler Neck	3829703		15.55
Cover, Gas Tank Compressor	3907628		140.30
Bow, Roof*	3797270		1.79
(*See Item 6 in Body Metal Frame)			
Bonding Strips, Roof*			
Front	3841907		2.51
Rear Side			
Front	3841906-5		3.08
Rear	3850832-1		1.85
Rear Upper	3824650		3.33
(*See Body Metal for Illustrations)			
Grille, Roof Ventilation			
Upper	3850824-3		3.23
Lower	3850826-5		3.23
Name Plate "Corvette"			
63-65	3797414		2.56
66-67	3873776		2.41

Cont'd.

Cont'd.

APRIL 1, 1972

CHEVROLET

CORVETTE 1963-67

ROOF, Cont'd.

HARDTOP

Top Assembly w/Hardware & Glass*	3912332	1.0	391.05
(*Paint as Required)	3926230		21.05
Panel, Front Header			
Header, Roof Panel			
Upper	3827470-69		9.85
Lower	3827468		9.85
Extension, Lower Header	3828796-5		3.08
Reinforcement Roof			
Side Outer	R. H. 3899814		12.35
	L. H. 3899813		11.55
Rear	3839636-5		4.20
Bow, Roof	3794142		26.40
Bracket, Roof Rear	3828266-5		1.50
Lock, Roof			
Header	3825178-7	.3	5.25
Rear Bow	3838237	.3	7.85
Guide, Header	3863876-5		2.40
Weatherstrip, Header			
Front	3846179		5.75
Side Center (2)	3828214		3.28
Extension & Side Rail			
63-64	R. H. 3827478 Disc.	.5	N. A.
65-67	R. H. 3846178	.5	11.85
63-67	L. H. 3846177 Disc.	.5	13.85
Bonding Strip, Roof*			
Front	3941907		2.51
Rear Side			
Front	3841906-5		3.08
Rear	3850832-1		1.85
Rear Upper	3824650		3.33
(*See Body Metal Frame for Illustrations)			
Cover, Vinyl Roof (Black)			
67	3900344	# 10.0	41.20
(*Including R&R Weatherstrip & Back Glass)			
Moulding, Garnish			
Header	3827166		4.10
Side Rear	3827174-3		2.15

BODY METAL FRAME

Time is w/Adjacent Panels removed.
Parts Listed in this Section are also
Listed in their proper Sections.

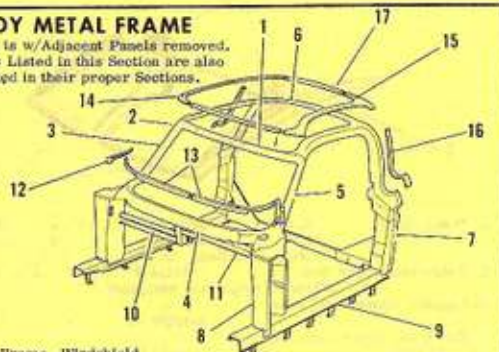

Frame, Windshield			
1. Upper	3829250 Disc.	1.5	5.00
2. Upper Corner			
Sport Coupe	3845814-3	1.5	10.80
Conv.	3829246-6	1.5	9.45
3. Side	3829252-1	2.5	10.00
4. Lower	3845846	1.5	16.20
5. Reinforcement, Door			
Front Opening			
Sport Coupe	3851064-3		9.00
6. Bow, Roof			
Sport Coupe	3797270		1.79
7. Pillar, Rear Lock Inner			
Sport Coupe (w/Reinforcement)	3865216-5	5.5	28.45
Conv.	3850684-3	5.0	24.30
8. Pillar, Front Hinge	3846388-7		16.20
9. Reinforcement, Rocker	3868744-3	3.5	8.20
10. Brace, Pillar	R. H. 3829257 Disc.	5.0	5.07
	L. H. 3866416		3.13

Cont'd.

BODY METAL FRAME, Cont'd.

BONDING STRIPS

12. Pillar to Fender Upper	3841904-3		1.85
13. Windshield Lower to Fender			
Upper	3842038-7		5.02
Roof Panel			
14. Front	3841907		2.51
Rear Side			
15. Front	3841906-5		3.08
16. Rear	3850832-1		1.85
17. Rear Upper	3824650		3.33

BACK WINDOW

Also order Installation
Materials as required



Glass, Window	(Car Mfr.)	(Glass Co.)		
Sport Coupe				
63	(D) C 3797038-7 1.7	Use NAGS B3182-1	Use	
	(D) T 3840026-5			
64-67	C 3847840	\$1.9 Glass NAGS B3288	Price	
	T 3847841			
Hardtop	C 3824779	\$1.0 Price NAGS N.A.	Price	
	T N.A.	List	List	
Conv.	C 3825818			

(*Add for Adhesive Kits)

Installation Materials Use as Required
(*2 Required if Old Adhesive Removed)

Weatherstrip, Glass			
63 Sport Coupe	3826042-1	Disc.	5.18
63-67 Hardtop	3827053		5.69

BACK WINDOW MOULDINGS

SPORT COUPE - 1963



Moulding, Reveal (w/o Clips)			
1. Upper	3825016-5		4.66
2. Lower	3825018-7	(D)	1.75
3. Outer (2)	3837941	(D)	1.05
Cap, Moulding Joint			
4. Outer Upper (2)	3825021		1.13
5. Lower (4)	3825023		.82
Moulding, Garnish			
Outer	3825172-1	Disc.	1.18
Inner	3825176-5	(D)	2.83
Lower	3825174-3	(D)	1.70

Cont'd.

CORVETTE 1963-67

CHEVROLET

BACK WINDOW, Cont'd.

BACK WINDOW MOULDINGS, Cont'd.

SPORTCOUPE - 1964-67



Moulding, Reveal (w/o Clips)

1. Upper	3847981	4.61
2. Lower	3847982	4.00
3. Outer	3841688-7	6.05
4. Cap, Moulding Joint (2)	3841679	1.33
Moulding, Garnish*		
64-67	R. H.	3899328 5.85
64-66	L. H.	3899327 5.69
67	L. H.	3899327 5.65

(*Paint as Required)

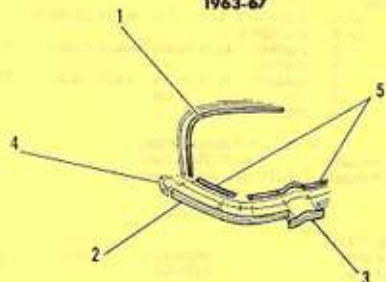
HARDTOP
1963-67

Moulding, Reveal (w/o Clips)

1. Upper	3827190-79	3.28
2. Lower	3827182-1	3.74
Cap, Moulding Joint		
3. Lower Center	3827183	1.49
4. Lower Side	3824308-7	.77
5. Retainer, Lower Moulding (3)	3823353	.41
Moulding, Garnish		
Center*	3837696	2.46
Sides	3837698-7	2.92

(*To be used when original Replaced with Superseded Mouldings)

QUARTER PANEL

Refinish Quarter 3.5
Pillar add .3
Pillar & Inner Panel is w/Outer Panel Removed.

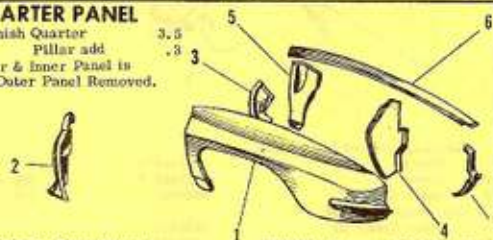

1. Panel, Outer Repair	3797020-19	#12.1	43.15
(*Cut Wheel Opening Rearward 9.3 ex. w/Roof Rear Panel Removed 4.6 w/Back Body Panel Removed 4.0)			

QUARTER PANEL, Cont'd.

Panel, Wheelhouse - Not Serviced, Use Underbody*

Panel, Wheelhouse Filler*

63-67	3908104-3	22.43
**See Underbody for Illustrations		
2. Pillar, Rear Body Lock	3846386-7	4.5 16.20
3. Panel, Pillar to W/House Filler	797380-79	1.0 7.83
4. Shield, Rear Splash		
63 (Conv.) (2)	3820924	1.0 (D) .58
63-67	3797166-5	1.0 6.85
5. Panel, Linkage Cover (Conv.)		
63-67	R. H.	3846390 1.2 10.65
63-67	L. H.	5846389 1.2 10.65
Bonding Strips		
6. Upper	3797092-1	8.90
7. Lower Rear		
63	3797154-3	3.90
64-67	3841538-7	3.33

REAR BODY PANEL - UPPER

Refinish One Side 1.5
Both Sides 2.5

EXC. SPORT COUPE

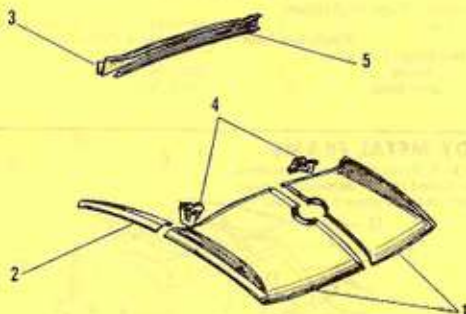

1. Panel, Upper	R. H.	3887499	#	56.10
	L. H.	3830277	#	53.30
(*One 6.9, Both 12.0)				
2. Extension, Upper Side		3832814-3	# 1.5	14.75
(*Time is w/Quarter Removed)				
3. Support, Upper Panel Rear		3843258		9.85
4. Extension, Upper Panel Support				
63 Only	R. H.	3830310		.82
	L. H.	3830309		1.13
Reinforcement				
Upper Panel Support				
5. Center		3824444		2.97
Side		3832530-29		.82
Filler, Upper Panel Support to Underbody		3843259		4.20
Door, Panel*		3874528		10.80
Berez Fuel Door Opening*				
63		3839710		.2 1.90
64-67		3847886		.2 2.05
(*See Roof for Illustrations)				
Name Plate "Corvette"				
63-65		3797414		2.56
66-67		3873776		2.41

Cont'd.

APRIL 1, 1972

CHEVROLET

CORVETTE 1963-67

REAR BODY PANEL - LOWER

Refinish Lower Panel 1.5



1. Panel, Lower Rear			
63-66	3878896	#8.6	33.00
67	3897425	8.6	33.00
(*w/ Roof Rear Repair Panels Removed 5.6)			
2. Panel, Lower Filler			
63	3797190	1.5	27.45
64-65 (exc. Side Mounted Exh.)	3877059	1.5	38.05
66-67 (exc. Side Mounted Exh.)	3874799	#	20.20
65-67 (w/ Side Mounted Exh.)	3863762	#	26.75
Banding Strip, Lower Panel			
3. Upper	3897426		10.00
4. Side Lower (63 Only)	3825872-1		1.85

REAR BUMPER



1. Face Bar	3797232-1	.5	44.45
2. Brace, Bar			
3. Outer	3848222-1		1.18
4. Center	3848224-3		1.33
5. Inner Upper	3848226-6	O/H 1.0	1.15
6. Inner Lower (2)	3797421		.51
7. Bezel, License Lamp	3797486		7.85

FUEL TANK

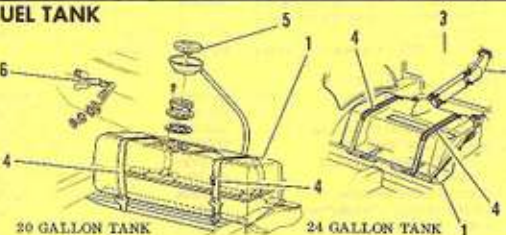

20 GALLON TANK			
1. Tank, Fuel			
24 Gallon w/ Filler Neck	3967746	2.4	34.80
2. Neck, Filler			
Sport Coupe			
w/20 1/2 Gallon Tank	3826413	.2	4.20
w/36 1/2 Gallon Tank	3794256	.2	27.45
Conv.	3923690	.2	3.02
3. Hose, Filler Neck			
All (2" I.D. x 16 3/4" O.L.)	3834073	.2	2.72
(2 1/4" I.D. x 15 1/2" O.L.)	3848526	.2	2.92
(1 3/8" I.D. x 12" O.L.)	3848525	.2	1.54
All w/36 1/2 Gallon Tank	3829421	.2	2.82
Support, Front Mounting	3841459		6.60
4. Strap, Mounting			.82
w/36 1/2 Gallon Tank*	3828315		
(*Cut 9 3/4" from Hook End & Rework.)			
5. Cap, Filler	3962708		2.26
Cap Unit, Locking	985919	Disc.	6.50
6. Gauge, Tank Unit			
w/20 1/2 Gallon Tank	6428065	1.3	20.90
w/36 1/2 Gallon Tank	6642798	1.3	18.45

REAR AXLE & SUSPENSION

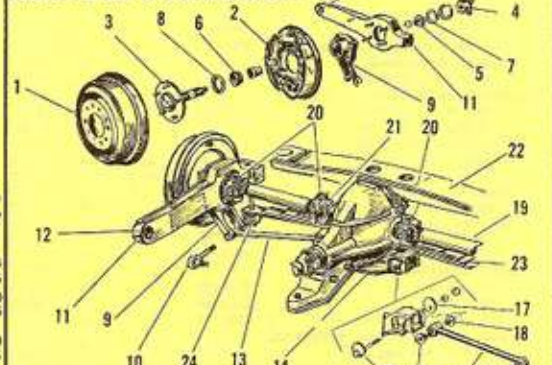

1. Drum, Rear Brake			
63-65 w/o Met. Brakes	3808801	.4	18.70
63-66 w/Met. Brakes w/o H. P. Eng.	3869537	.4	18.70
63-64 w/Met. Brakes, w/H. P. Eng.	3841831	.4	19.75
Disc, Rear Brakes			
65-67	3865906	1.6	51.00
Housing, Brake Caliper (Less Shoes)			
Inner			
65-67 (1st Design)	5467293-2	#	21.05
67 (2nd Design)	5461992-1	#	37.35
Outer			
65-67 (1st Design)	5467536-5	#	21.05
67 (2nd Design)	5462017-6	#	37.10
(*65-66 2.4, 67 2.2)			
2. Back Plate, Brake			
63-65 w/o H. P. Eng.	3847720-19 Disc.	1.5	4.92
63-64 w/H. P. Eng., R.H.	3847722 Disc.	1.5	20.15
L.H.	3847721 Disc.	1.5	22.75
65-67	5465983-2		5.50
Hose, Rear Brake			
Standard Brake	3578958	#	6.15
H/Duty Brake	3878958	#	6.15
(*One .6, Both .8)			
3. Spindle, Rear Wheel (w/Bolts)			
63-65 w/o Disc Brakes	3829239	2.3	29.55
65-67 w/Disc Brakes	3872476	2.6	29.55
4. Flange, Spindle	3839830		16.55
Bearing, Rear Wheel			
5. Inner (2)	7451262		5.45
6. Outer (2)	7450709		5.00
Seal, Wheel Bearing			
7. Inner	3794062		.97
8. Outer	3794066		.97
9. Support, Spindle	3826644-3	#	17.30
(*2.7 exc. w/Disc Brake 3.5)			
10. Shaft, Support			
Standard Suspension	3820930-29		7.05
H/Duty Suspension	3829266-5		6.90
11. Arm Assembly, Torque Control			
63-65 w/o Disc Brakes	3861536-7	#5	44.15
65-67 w/Disc Brakes	3874770-69	#5	43.05
(*w/Spindle Support Removed)			
12. Bushing, Torque Arm (2)	3742857		1.18
13. Strut, Spindle Support (2)	3819205	.7	7.60
14. Bracket, Support Strut	3817827	.6	4.92
15. Bushing, Strut	3776762	.7	1.85
Cam, Strut			
16. Front w/Bolt	3820253	.7	.62
17. Rear	3790331	.7	.20
18. Cap, Strut Bushing	3791519		.05
19. Shaft, Rear Axle	3872908	#1.4	23.30
(*Including R&R Inner & Outer Universal Joints)			
20. Universal Joint Kit, Rear Axle (4)	3829696	#	9.90
(Inner .3; Outer .4, w/Axle Shaft Removed.)			
21. Yoke, Rear Axle Universal Joint			
w/327 Eng., w/o Pos. Traction	3832031		11.95
All w/Pos. Traction	3872922		16.55
Flange, Universal Joint Yoke	3843018		10.85

Cont'd.

CORVETTE 1963-67

CHEVROLET

REAR AXLE & SUSPENSION, Cont'd.

22. Crossmember					
Suspension Mounting	3949087			33.85	
Cushion, Crossmember Rear (2)	9750078			4.25	
Support, Suspension					
Outer Mounting (2)	3775513			5.50	
23. Spring, Rear (Leaf)					
Standard (9 Leaves)	3977579		1.0	51.80	
H/Duty (7 Leaves)	3977578		1.0	N. A.	
Main Leaf, Spring (No. 1)					
Standard	3853020	Disc.	1.4	4.80	
H/Duty	3828812	Disc.	1.4	5.99	
Plate, Spring Anchor	3817582			1.85	
24. Cushion, Spring Mounting (4)	3831986		.4	.25	
Retainer, Spring Cushion					
Inner (2)	3910701		.4	.30	
Outer (4)	3960701		.4	.15	
Shock Absorber (w/Bushing)					
Standard	3102972		.4	13.25	
H/Duty	4960459		.4	18.20	
Bushing, Shock Lower (4)	3735334		.4	.15	
Shaft, Rear Stabilizer (w/Bushing)					
w/396, 427 Eng.	3967713		1.3	16.35	
Bushing, Stabilizer Shaft					
w/396, 427 Eng.	3872955		.4	.67	

REAR LAMP

TAIL, STOP & DIRECTIONAL LAMP

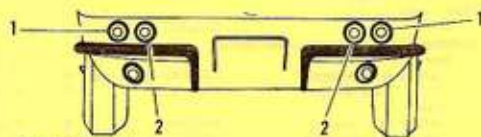

Lamp Assembly

1. Outer	910554-3	.4	11.80
2. Inner (w/o Back-Up Lamp)	910555-7	.4	11.80
Lens (4)	5964803		1.44
Gasket, Mounting			
Lens	5948748		.25
Lamp	5362101		.62
Bulb, Lamp (No. 1157)	9428902		.94

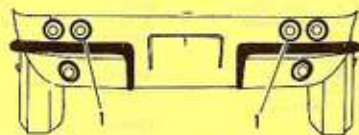
BACK-UP LAMP
1963-66

1. Lamp Assembly	910428-7	.4	7.70
Lens (Clear)	5948757	.2	1.28
Gasket, Mounting			
Lens	5948748		.25
Lamp	5362101		.62
Bulb (No. 1156)	9417866		.57

BACK-UP LAMP
1967

1. Lamp Assembly	911490-89		5.70
Lens	5969242-1		2.31
Gasket, Mounting			
Lens	5959240		.77
Bulb (No. 1156)	9417866		.57

Cont'd.

REAR LAMP, Cont'd.

LICENSE LAMP



Lamp Assembly	898005	.7	2.56
Lens	5361010		.77
Gasket, Mounting			
Lens	5951008		.56
Bulb (No. 67)	9421777		.31

CONVERTIBLE TOP

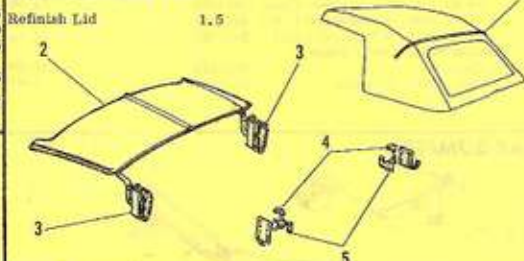

1. Top Assembly

Black	3831866	3.5	318.50
White	3831867	3.5	318.50
Beige	3831868	3.5	318.50
Dark Blue	3907135	3.5	318.50

Cover, Top Trim*

Black	3839728	6.0	90.15
-------	---------	-----	-------

Curtain & Window, Rear*

Black	3831992		34.70
-------	---------	--	-------

(*For Colors not Listed, Call Local Dealers)

2. Lid, Folding Top Compartment

Trim Panel, Compartment Lid*	3871090	1.0	100.60
------------------------------	---------	-----	--------

Black

3871092	Disc.		9.60
---------	-------	--	------

(*For Colors not Listed, Call Local Dealer)

Panel, Linkage Cover			
63-67	R. H.	3846390	10.65
	L. H.	3846389	10.65

3. Hinge, Compartment Lid	3930948	.3	4.10
---------------------------	---------	----	------

4. Plate, Lock Wear	3928830		.30
---------------------	---------	--	-----

5. Lock, Compartment Lid	3915781	.2	5.60
--------------------------	---------	----	------

Striker Plate, Lock	3778599	.2	.52
---------------------	---------	----	-----

Control Lock Remote	3845236		3.43
---------------------	---------	--	------

Weatherstrip, Compartment Lid	3826967	.4	5.45
-------------------------------	---------	----	------

Lock, Folding Top			
Header	3825178-7		5.25

Rear Bow (2)	3838257		7.85
--------------	---------	--	------

Pin, Rear Bow Lock	3822946-5		5.75
--------------------	-----------	--	------

Striker, Header Lock			
(w/Bushing)	3826368-7		2.67

Panel, Front Header	3826230	3.0	21.05
---------------------	---------	-----	-------

Rail, Side			
Front	3824644-3		11.30

Center	3824656-5		13.35
--------	-----------	--	-------

Rail Assembly, Rear			
w/Bow & Link	3887438		208.00

Weatherstrip, Rail			
Header	3846179	.3	5.75

Side Front	3846176-5	.3	11.70
------------	-----------	----	-------

Center	3825214	.3	3.28
--------	---------	----	------

Rear Upper	3828294-3	Disc.	.3
------------	-----------	-------	----

Lower	3850654-3	.3	3.23
-------	-----------	----	------

Row, Top			
No. 1 63-65	3873719		12.70

66-67	3873719		12.70
-------	---------	--	-------

No. 2	3834344		12.70
-------	---------	--	-------

No. 3	3824345		17.55
-------	---------	--	-------

Link, Control			
Front	3797209		2.92

Rear Side	3824342-1		5.40
-----------	-----------	--	------

Bracket, Rear Bow Pivot	3826022-1		3.23
-------------------------	-----------	--	------